

Empty Weldment Cut-List Table

TITLE: Troubleshooting a blank Cut List table in a Drawing

DATE: November 2014

A weldment cut list table can be inserted into a drawing by going to Insert>Tables>Weldment Cut List. However, sometimes this table is inserted without any values, as seen in the image below.

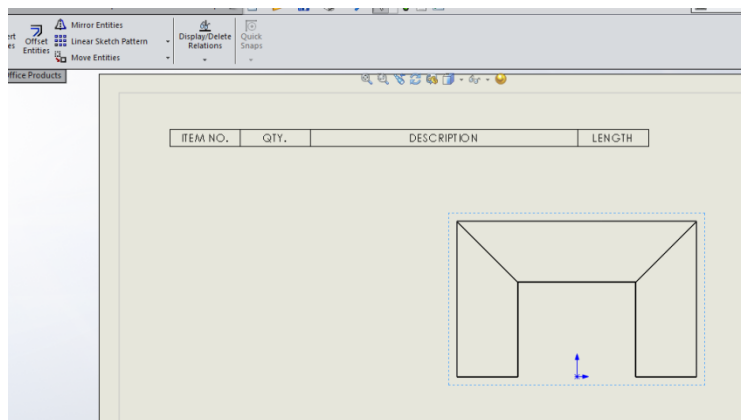

The most likely reason for an empty table is that the cut list needs to be updated. Open the weldment part. In the feature tree, right click on "Cut List" and select "Update." The table should now be populated in the drawing.

